



EOSV2 - EOS60SS2

CONVENTIONAL OVEN



EOS60SS2/ EOSV2 v3c



Barcode 8422248603348 / 8422248600262

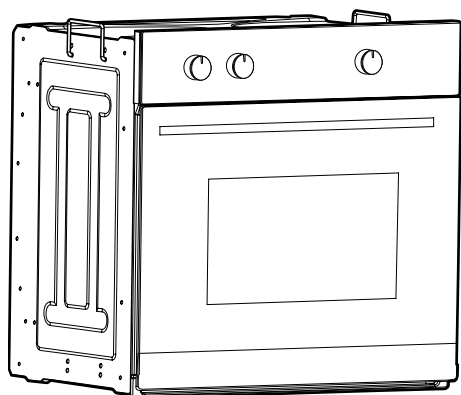

[01] x 1

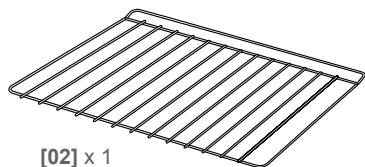

[02] x 1

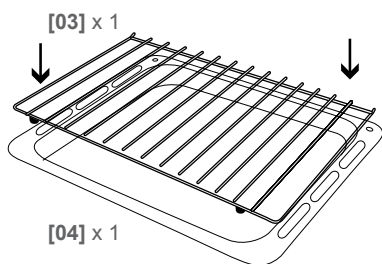

[04] x 1

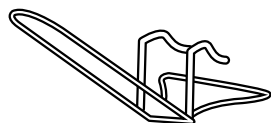

[05] x 1



[06] x 4



[07] x 4
(Ø3.9 x 32 mm)



EOS60SS2 - EOSV2

GB **IE** Built In Conventional Oven

04

Installation

28

Let's get started...



Getting started...

05

Before you start
Safety

06
09

In more detail...

11

Product functions
Operation
Care and maintenance
Troubleshooting
Recycling and disposal
Technical and legal information
Guarantee
CE Declaration of conformity

12
14
16
20
21
22
25
27

Appendix

Installation

28



Getting Started...

Before you start 06

Safety 09

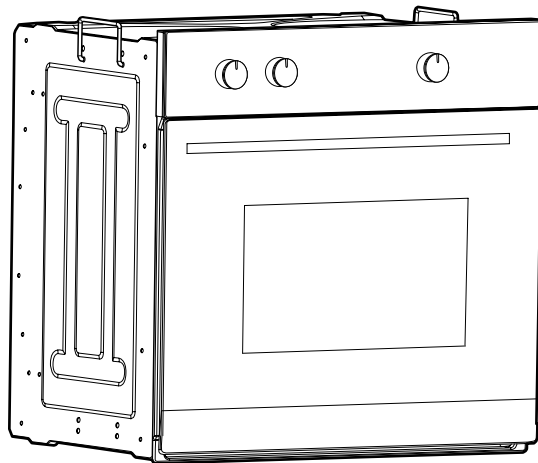

Before you start

- To avoid the risks that are always present when you use an electrical appliance it is important that this appliance is installed correctly and that you read the safety instructions carefully to avoid misuse and hazards. Please keep this instruction booklet for future reference and pass it on to any future owners. After unpacking the appliance please check that it is not damaged. If in doubt, do not use the appliance but contact Customer Services on 0844 800 1128 (UK), 1 800 535542 (Ireland) and 01 56 48 02 60 (France).
- Check the package and make sure you have all of the parts listed.
- Decide on the appropriate location for your product.
- If this product contains glass please take care when fitting or handling to prevent personal injury or damage to the product.

The specifications plate is available on this appliance. This plate displays all the necessary identification information for ordering replacement parts.

If you sell the appliance, give it away, or leave it behind when you move house, make sure you also pass on this manual so that the new owner can become familiar with the appliance and its safety warnings.

Instructions

- This user manual must be kept for future reference and use by someone who is not familiar with the appliance.
- Before using the oven, carefully clean the inside with a non-abrasive detergent and warm water. Position the grill and tray in their respective runners. Once the operation is complete, turn the oven on to the maximum temperature for approximately 20 minutes to remove any traces of manufacturing grease, oil or resins which may cause unpleasant odours when cooking.

Prior to start up of the appliance

- WARNING:** During this first use some smoke or unpleasant odours may appear. Should this happen ventilate the room suitably until the first operation is finalised.
- Once this simple operation has been carried out the oven is ready to use for cooking.
- This appliance is exclusively for domestic use.
- Use the oven to cook food only.
- Before cooking, make sure all oven accessories that are not required are removed from the oven.
- Pre-heat the oven to the cooking temperature before using it.
- Place the cooking trays in the centre of the oven and leave space in between when using more than one, so that the air can circulate.
- Do not put oven trays on the base of the oven or cover it with aluminium foil. This will cause thermal accumulation. The cooking and roasting times will not coincide and the enamel may be damaged.
- Try to open the oven door as little as possible to see the food (the oven light remains on during cooking).
- Take care when opening the door to avoid contact with hot parts and steam.

Tools Required

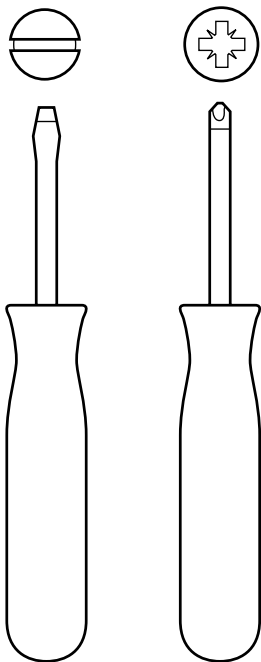

We advise when installing this appliance two people are recommended.

These instructions are for your safety. Please read through them thoroughly prior to installation and retain them for future reference.



- All installation work must be carried out by a competent person or qualified electrician.
- This appliance must be installed correctly by a suitably qualified person, strictly following the manufacturer's instructions.

- This appliance complies with all current European safety legislation, however, the Manufacturer must emphasise that this compliance does not prevent the surfaces of the appliance from heating up during use and remaining hot during its operation.
- Accessible parts may become hot during use. Young children should be kept away. Care should be taken to avoid touching the appliance (e.g hob, cooker).
- The Manufacturer highly recommends that this appliance be kept out of the reach of babies and small children.
- Children should be supervised to ensure that they do not play with the appliance.
- This appliance is not intended for use by persons (including children) with reduced physical sensory, or mental capabilities, or by those who lack experience and knowledge, unless they have been given supervision and instruction concerning the use of the appliance by a person responsible for their safety.
- Means for disconnection must be incorporated in the fixed wiring in accordance with the wiring rules. An all-pole disconnection switch having a contact separation of at least 3 mm in all poles should be connected in fixed wiring.
- Do not allow the electric cables to touch the hot parts of the appliance.
- Make sure that the power cord is not caught under or in the appliance and avoid damage to the power cable.
- Do not install the appliance outdoors in a damp place or in an area which may be prone to water leaks such as under or near a sink unit. In the event of a water leak allow the machine to dry naturally.
- Please dispose of the packing material carefully.
- Do not use flammable sprays in close vicinity to the appliance.

- We also recommend that great care be taken during use and cleaning. Read the cleaning and maintenance sections for this appliance carefully.
- A steam cleaner is not to be used.
- The appliance is not intended to be operated by means of external timer or separated remote-control system.
- The appliance is for domestic use only.
- Do not place heavy objects on this oven or lean on the door when opening it, as this may damage the hinges.
- Do not leave hot oil or fats unattended as they may catch light.
- Do not place oven dishes or trays of the base part of the oven or cover it in aluminium foil.
- Do not install the appliance near curtains or upholstered furniture.
- Do not try to lift or move kitchen appliances by pulling any door or handle as this may cause damage.
- If the oven seal is very dirty, the door will not close properly when the oven is working. The fronts of neighbouring furniture may be damaged. Keep the oven seal clean.
- Open the oven carefully as hot steam may escape.
- Do not pour water inside a very hot oven. The enamel may be damaged.
- Heat, vapour and humidity are produced during use, avoid all kinds of personal damage and ensure that the room is suitably ventilated. If used for a prolonged period of time, additional ventilation may be necessary. Consult a qualified installer if you have any doubts about the necessary volume.
- The Manufacturer declines all liability for personal or material damage as a result of misuse or incorrect installation of this appliance.







In more detail...

Product functions	12
Operation	12
Care and maintenance	16
Troubleshooting	20
Recycling and disposal	21
Technical and legal information	22
Guarantee	25
CE Declaration of conformity	27

Product functions

- > The oven is controlled by a thermostat between 50 °C and 250 °C, depending on the temperature required. The thermostat pilot light turns on and off to indicate the temperature control during use.
- > The required cooking mode is selected using the multi-functional control button. The functions that may be selected are:

	Oven Light	Turning control knob to this setting, the oven light will illuminate in the oven cavity, and will operate on all selected functions.
	Conventional	Upper and lower heating element come on. Heat is distributed by natural convection and this means the top half of the oven is warmer than the bottom half, food should be placed on a higher shelf if the food is to be crisped. It is recommended that the oven is pre-heated for 10-15 minutes before commencing cooking.
	Lower Element	Lower element comes on, heat radiates by natural convection from the base of the oven.
	Grill	Grill element comes on and is dispersed by radiant heat.

- > Oven door should be open when using grill function
- > Read the information of the food packaging for the cooking temperatures and times. Once familiar with the performance of the appliance, the temperatures and times may be varied to adapt them to your personal tastes.
- > Check that frozen food is completely thawed before cooking, unless indicated otherwise.





The information given in the following charts is intended only as a guide. Select the lowest temperature quoted and check the food at the end of the shortest duration quoted.

Cooking instructions

	CONVENTIONAL		
Cakes/Biscuits	Temperature °C	Shelf Position (Recommended) from the bottom	Cooking Time in min.
Cake Mixture Desserts in Moulds			
Sponge cake	150 – 170	1	60 – 70
Marble, nut cake (tin)	150 – 170	1	60 – 80
Fresh fruit cake (tray)	170 – 190	2	45 – 50
Flan base	170 – 190	1	20 – 25
Biscuits (tray)	170 – 190	2	20 – 20
Sponge cake (3 to 6 eggs) 3)	170 – 190	1	20 – 35
Swiss roll	180 – 200	1	12 – 16
Short Pastry Dessert in Moulds			
Tart / flan base	170 – 190	2	15 – 20
Streusel cake	170 – 190	2	45 – 55
Cheesecake	170 – 190	2	10 – 20
Apple pie	170 – 190	1	90 – 90
Apricot tart with topping	170 – 190	1	55 – 75
Raised Dough Dessert in Moulds			
Streusel cake	170 – 190	1	35 – 45
White bread	180 – 200	1	40 – 50
Pizza (tray)	190 – 210	1	35 – 45
Onion tart	180 – 200	1	25 – 35
Apple turnovers	160 – 180	2	25 – 30
Choux pastry, Eclairs	180 – 200	2	25 – 35
Puff Pastry	190 – 210	2	15 – 25
Meringues, Macaroons	120 – 140	2	25 – 50

> Pre-heat the oven for 10 mins.

	CONVENTIONAL		
Food	Recommended shelf level from the bottom	Temperature °C	Time in min.
Roast beef, approx. 1 kg	1	190 – 210	100 – 120
Beef fillet, approx. 1 kg	1	200 – 220	45 – 55
Venison, approx. 1 kg	1	190 – 210	90 – 120
Pork joint, approx. 1 kg	1	200 – 220	100 – 120
Pork joint, approx. 2 kg	1	180 – 200	120 – 150
Ham joint, approx. 1 kg	1	200 – 220	60 – 70
Meat loaf, approx. 1 kg	1	190 – 210	70 – 80
Veal, approx. 1.5 kg	1	190 – 210	100 – 120
Leg of lamb, approx. 1.5 kg	1	220 – 220	90 – 120
Rack of lamb, approx. 1.5	1	190 – 210	50 – 60
Poultry, 0.8 – 1 kg	1	190 – 210	60 – 70
Poultry, approx. 2 kg	1	190 – 210	90 – 110
Poultry stuffed, approx. 2	1	190 – 210	110 – 130
Poultry, approx. 4 kg	1	180 – 200	150 – 180
Fish, whole, approx. 1.5 kg	1	190 – 210	35 – 55

	GRILL		
Food	Recommended shelf level from the bottom	Temperature Setting	Total grilling Time in min.
Thin cuts			
Steak	3 or 4	maximum	10 – 16
Kebabs	3	maximum	25 – 30
Chicken kebabs	3	maximum	20 – 25
Cutlets/Schnitzel	3 or 4	maximum	12 – 18
Liver	3 or 4	maximum	8 – 12
Burgers	3 or 4	maximum	14 – 20
Sausages	3 or 4	maximum	10 – 15
Fish fillet	3 or 4	maximum	12 – 16
Trout	3 or 4	maximum	16 – 20
Toast	3 or 4	maximum	2 – 4
Cheese toast	3 or 4	maximum	7 – 9
Tomatoes	3 or 4	maximum	6 – 8
Peaches	2	maximum	6 – 8
Thicker cuts			
Chicken (approx. 1 kg)	1	maximum	50 – 60
Rolled meat, 7 cm, (approx. 1 kg)	1	maximum	75 – 85
Pork (approx. 1 kg)	1	maximum	100 – 120
Sirloin (approx. 1 kg)	1	–	–

- > Turn half way through the grilling time.
- > Select the appropriate shelf level for the thickness of the food.
- > If you use the grill function, the door has to be kept slightly opened.
- > The grill power can be regulated by the temperature control knob.

**CAUTION**

The oven door becomes hot during use of the grill.

Using The Mechanical Timer (Fig 1)

Once the thermostat controls are in the desired position, turn the knob clockwise to the maximum position and then turn it anti-clockwise to the desired time; at the end of this set time the buzzer will sound. The timer only indicates the end of the set time, but it does not stop the function being used.

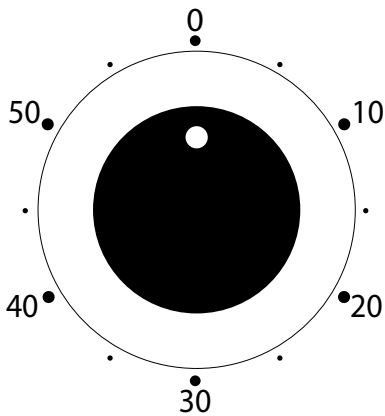

FIG 1

Care and maintenance



Warning

Always switch off the electricity supply before performing maintenance work. In the event of a fault, contact customer services.

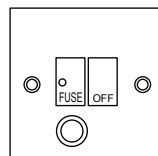

- ① Cleaning an oven that does not feature self-cleaning panels must be done after use, when it is switched off but still warm, not hot, so that the film of grease produced by the cooking vapours on the walls is still easy to remove, as well as the drips and splashes of fat that are not yet hard and dry.
- ② To clean the stainless steel external parts, use a soft cloth with soap and water; do not use any powdered products that contain abrasive substances.

Normally, wiping with a damp soft cloth and warm detergent is enough, but for stubborn stains the following is recommended:

Cleaning the oven cavity

- > Spray a proprietary oven cleaner inside your oven and leave it to work for the time specified in the manufacturers instructions. Then use a clean sponge to wipe off the foam residue.
- > Wear rubber gloves to prevent the cleaner coming into contact with your skin and make sure the kitchen is well-ventilated to disperse the fumes produced by the cleaner. Repeat if necessary.
- > Also avoid the use of acid or alkaline substances (lemon juice, vinegar, salt, tomatoes, etc.). Avoid using products containing chlorine, acid or abrasive substances specially for cleaning the varnished walls. Do not use thick steel wool or hard utensils, as they can damage the surface finishes.
- > Do not use high pressure cleaners or steam appliances for cleaning the oven.
- > Only use a recommended cleaner for this type of material – avoid chloride-based products such as bleach.

Removing the door from the oven (Fig.1)

- > To simplify cleaning the interior of the oven, the door can be removed.
The process of removing the door is shown below:
- > Open the door fully to position "C"
- Lift the two mobile links "A" of the hinges, until fixing at point "B".
- > Then close the door to the half-way position.
- > Next, lift the door upwards and remove it, sliding it outwards; hold the door by the sides close to the hinges when doing this.
- > To replace the door, first slide the hinges into their grooves and open the door completely.
- > Remember to turn the two moving links "B" used to engage the two hinges before closing the door (Fig.1).

WARNING

- Take care not to remove the hinge locking system when taking off the door, as the hinge mechanism can spring back suddenly.
- Never submerge the door in water for any reason.

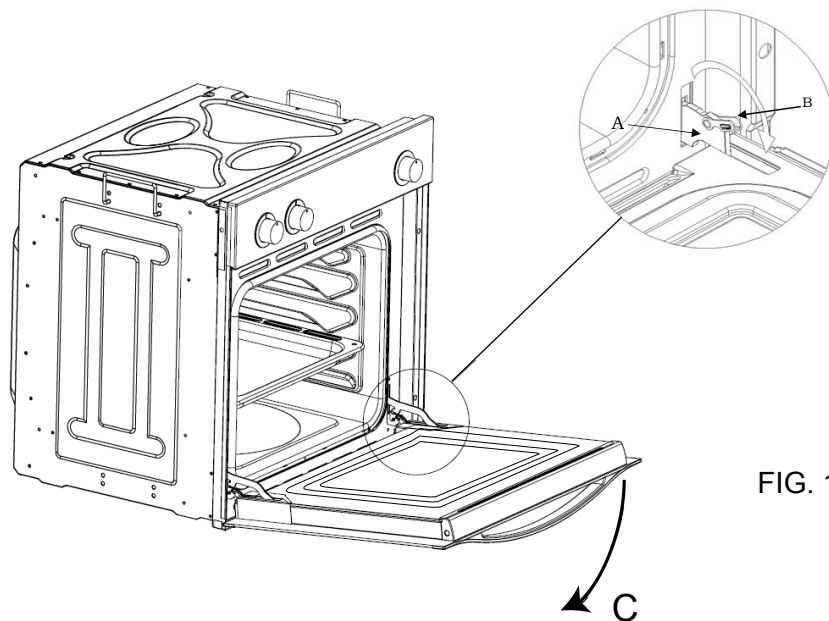

FIG. 1

Cleaning the glass door (Fig.2)

- > If possible, remove the oven door glass following the manufacturer's instructions. Use warm water with a little detergent to clean the glass sections of the door.
- > Do not use abrasive products which could damage the glass. Remember that if the surface of the glass panel becomes scratched, it could cause a dangerous failure.
- > To simplify the cleaning, the inner glass panel can be taken out of the door. The method for removing the glass from the door is shown below.
- > After removing the screws fixing the glass, located on the inner face of the door, lift the glass out carefully. In versions with three glasses the intermediate glass can also be removed. The procedure is the same as above.

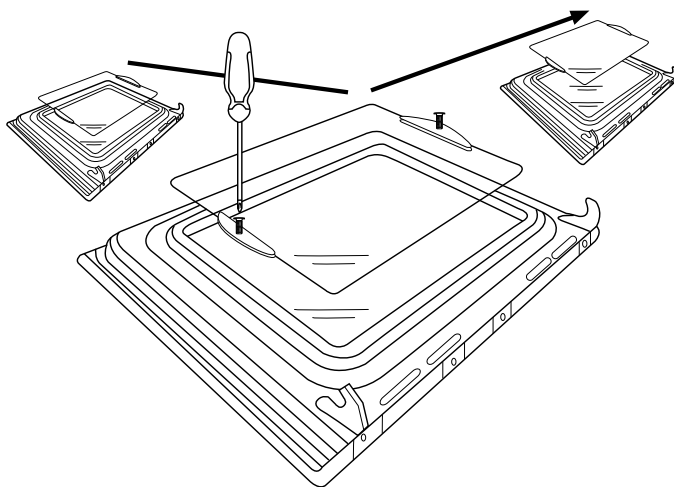
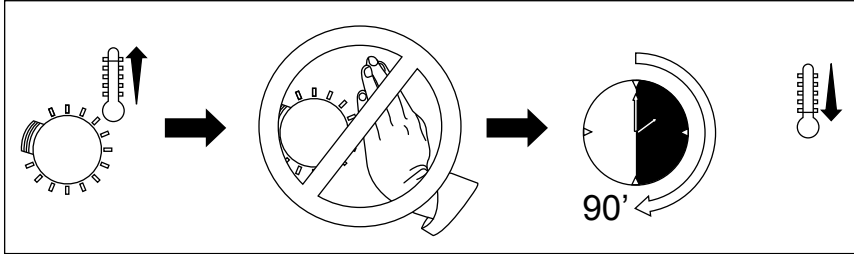

FIG.2

Replacement of the oven light bulb (Fig. 3)

> Not covered by the appliance guarantee.



WARNING: Disconnect the appliance from the electricity supply, open the oven door remove the oven shelves.

The oven has a light with the following characteristics:

> 15 W or 25 W, 300 °C and type E-14

1. During use the appliance becomes hot. Care should be taken to avoid touching heating elements inside the oven
2. **WARNING:** Ensure that the appliance is switched off before replacing the lamp to avoid the possibility of electric shock
3. Remove the glass cover that protects the light bulb by turning it anti-clockwise.
4. Unscrew the old light bulb and dispose of it safely and ecologically, change it for one as specified in the "Technical data" and replace the cover.

Note: The glass cover may be tight and, therefore, may need a grip to release it.

FIG.3

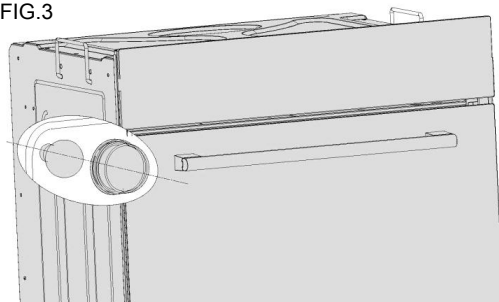
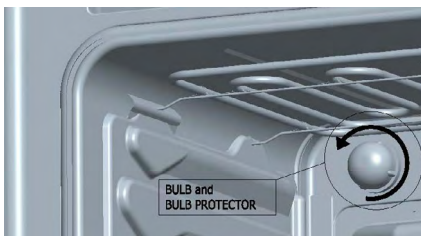

Troubleshooting

Fault	Cause	Solution
Oven doesn't work	Something at the connection is wrong, or it's not connected.	Turn off main supply and check if some wire has been disconnected.
	Power supply connections are loose.	Turn off main supply and check if some wire has been disconnected.
	Something at house installation is wrong.	Turn off main supply and check if some wire has been disconnected.
Oven light doesn't work	Light bulb is blown.	Replace bulb as described in the manual in the section "Care and maintenance".
Oven will not heat	No function is selected.	Choose a cooking function turning the selector.
	No temperature is selected.	Choose a temperature turning the selector.
Grill not heating properly	The grill power set too low.	Turn the temperature control knob to maximum.

Recycling and Disposal

Environmental Protection

Waste electrical products should not be disposed of with household waste. Please recycle where facilities exist. Check with your Local Authority or retailer for recycling advice.



The symbol on the product or its packaging indicates that this product cannot be treated as normal household waste. This product must be handed over to an electric and electronic equipment collection point for recycling.

On ensuring that this product is disposed of correctly, you will help to avoid possible negative consequences for the environment and public health, which could occur if this product is not handled correctly. To receive more detailed information about recycling this product, contact your local government, domestic waste disposal services or the outlet where the product was bought.

Technical data

Interior dimensions:

Height:	340 mm
Width:	440 mm
Depth:	390 mm

Model Name	Gross Volume (LITRES)	Net Volume (LITRES)
EOSV2	59	52
EOS60SS2	59	52

Electrical information:

Nominal voltage:	220 V – 240 V~ 50 Hz
Power connection:	13 A (automatic bipolar switch with protected socket, with 3 mm separation between contacts)

Power absorption:

Base Resistance:	1.30 kW
Roof Resistance:	0.90 kW
Grill Resistance:	1.35 kW

Network power cable:

3 x 1.5 mm² type H07RN-F <HAR>

Oven light bulb: 15 W – 25 W / 300 °C screw type E-14

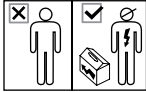

All installation work must be carried out by a competent person or qualified electrician. Before connecting the mains supply ensure that the mains voltage corresponds to the voltage on the rating plate inside the cooker hood.

Warning: THIS APPLIANCE MUST BE EARTHED.

Mains Supply could be connected to the Mains Voltage by Direct Connection

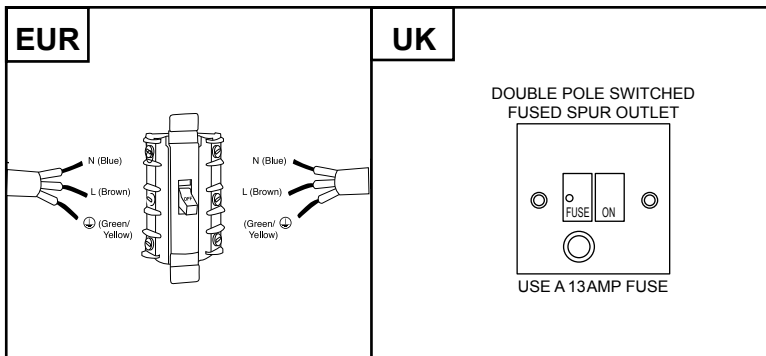

Direct Connection

If the appliance is being connected directly to the mains an omnipolar circuit-breaker must be installed with a minimum opening of 3mm between contacts.

If the cable is damaged or to be replaced, the operation must be carried out by a qualified electrician with dedicated tools to avoid any accidents.

The installer must ensure that the correct electrical connection has been made and that it complies with wiring diagram.

The cable must not be bent or compressed.

The cable must be checked regularly and replaced by authorized technicians only.

Electrical Requirements

Any permanent electrical installation must comply with the latest I.E.E. Regulations and local electricity company regulations. For your own safety a qualified electrician or contractor who is on the roll of the National Inspection Council for Electrical Installation Contracting (NICEIC) should undertake the electrical installation.

Electrical Connection

Before connecting the mains supply ensure that the mains voltage corresponds to the voltage on the rating plate inside the appliance.

WARNING: THIS APPLIANCE MUST BE EARTHED

The appliance is supplied with a 3-core mains cable and must be connected to the electricity supply via a double pole switch having a 3mm minimum contact gap on each connector.

For UK only
A Switched Fused Connection Unit to BS 1363 Part 4 is recommended.

The fuse must be rated at 13 Amps.

The wires in the mains lead are coloured in accordance with the following code:

Brown = L - Live

Blue = N - Neutral

Green and Yellow = ⊕ - Earth

The connection point must be placed in a position adjacent to the appliance so as to be readily accessible for an engineer in the event of a breakdown.

Disconnect the appliance from the mains supply before carrying out any kind of maintenance or cleaning.

Manufacturer's Guarantee

This appliance is covered by a full manufacturer's 24 month parts and labour guarantee and covers all parts and labour costs associated with the repair of the appliance in a domestic environment. We will repair any defect that arises due to faulty materials or workmanship and use genuine manufacturers parts.

All claims must be supported with the original receipt or other reasonable proof of purchase.

If, during the guarantee period, the appliance becomes irreparable as agreed by the engineer approved by GAA then we reserve the right, at our discretion, to exchange the defective product with a replacement appliance at GAA's sole cost. If the same product is no longer available an alternative will be offered with the same functions as the faulty item.

After an appliance has been repaired or replaced any remaining balance of the GAA guarantee will be valid and any further call outs during this prescribed period will be covered by GAA on the replacement appliance.

Should any person other than an authorized engineer modify or attempt to repair the appliance then the warranty will be invalid.

The guarantee applies to the UK mainland, Scotland, Ireland, ROI and France but is not transferrable between EU countries.

This guarantee is non-transferrable to any other person or product. The guarantee is covered by UK law and is in addition to and does not diminish your legal rights.

Exclusions to the guarantee

This guarantee does NOT cover:

Appliances that have been damaged or neglected as a result of failure to store, assemble, install, use or care of the products in accordance with the manufacturer's instructions - GAA will not accept responsibility under this guarantee if a product is damaged or becomes defective due to, misuse, neglect, wilful or accidental damage or act of god.

Normal wear and tear.

Consumable items such as carbon filters and bulbs.

Exclusions to the guarantee (continued)

Claims arising from non-domestic use or commercial environment.

Any gas appliance not fitted by a gas safe qualified installer.

If no fault is found then GAA reserves the right to charge for the call out at the going rate of £55.00 plus VAT.

In the course of the service work carried out it may be necessary to remove the built in appliance from its fitted position. If the appliance is glued, grouted or tiled in such a manner that it cannot be removed, it is the responsibility of the customer/installer to remove and reinstall the appliance to facilitate the repair.

This Guarantee does not affect your statutory rights.

The guarantee is offered by GAA Ltd, 1301-1303 Lu Plaza, 2 Wing Yip St, Kwun Tong, Kowloon, Hong Kong.

Customer Service

To arrange an in guarantee service call, please contact customer services on the following numbers.

UK and N.Ireland – ISDAL Customer Care Centre
T: 0844 8001128 E: uksupport@cnagroup.hk
www.myspareparts.co.uk

Republic of Ireland (ROI) – ISDAL Customer Care Centre
T: 1-800 535542 E: uksupport@cnagroup.hk

CE Declaration of Conformity



MANUFACTURER: CATA

ADDRESS: C/Ter n° 2, Torelló 08570 – Barcelona (Spain)

We hereby certify that the mentioned accessory complies with the essential requirements of the European Directives applicable, including their modifications and the corresponding transpositions from the national law.

MACHINE APPLICATION: EOS60SS2, EOSV2

TYPE: OVEN

**EC DIRECTIVES APPLIED: EC Symbol - 2006/95/EEC Low voltage - 73/23
CEM-89/336**

APPLIED HARMONIZED STANDARDS: Safety Rules - EN 60 335-1, EN 60 335 - 2 - 6

APPLIED INTERNATIONAL TECHNICAL STANDARDS AND SPECIFICATIONS: ISO9001:2008

PLACE: Torelló

David Sala

Technical Manager

This appliance respects laws of the suppression of radio-interference.
As the Manufacturer has a policy of continuous product improvement, it reserves the right to adapt and carry out any modification considered necessary without prior warning.

In more detail...

Appendix...

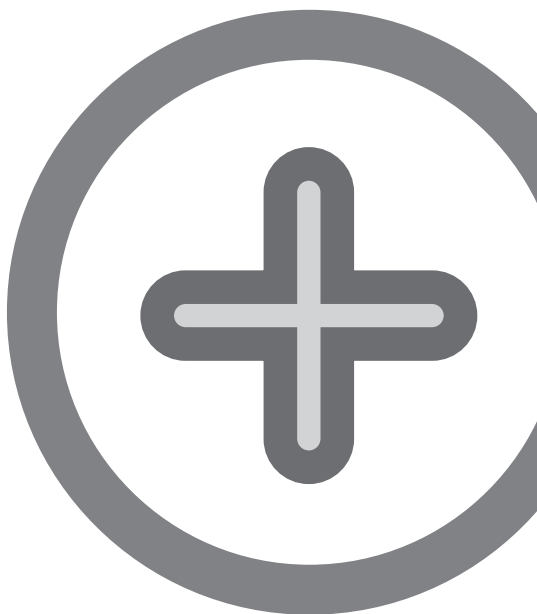

Installation

Fitting the appliance

Important

- > The adjacent piece or furniture or cupboard and all the materials used in the installation must resist a minimum temperature increase of 85 °C above the ambient temperature during use of the appliance.
- > Certain types of vinyl or laminated kitchen furniture are particularly susceptible to damage due to decolouration at temperatures below those indicated.
- > If the appliance is installed without paying attention to this temperature limit or if it is placed less than 4 mm from the adjacent cupboards, liability will belong to the owner.

Installation Notes

1. The oven has to be installed in a standard gap of 600 mm, as indicated in Fig. 4, whether under a hob or in a column.
2. On inserting the oven in a column, it is essential in order to ensure there is enough ventilation, to remove the rear panel of the furniture and have an opening of at least 85 – 90 mm as indicated in Fig. 4.
3. Check that the oven has been fixed securely in the housing. Fixing the oven into the cupboard is done using 4 screws. One in each corner of the oven door frame.

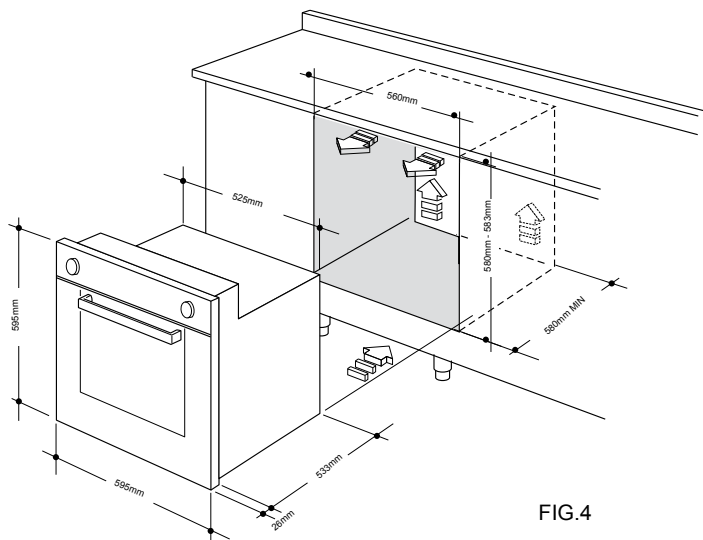
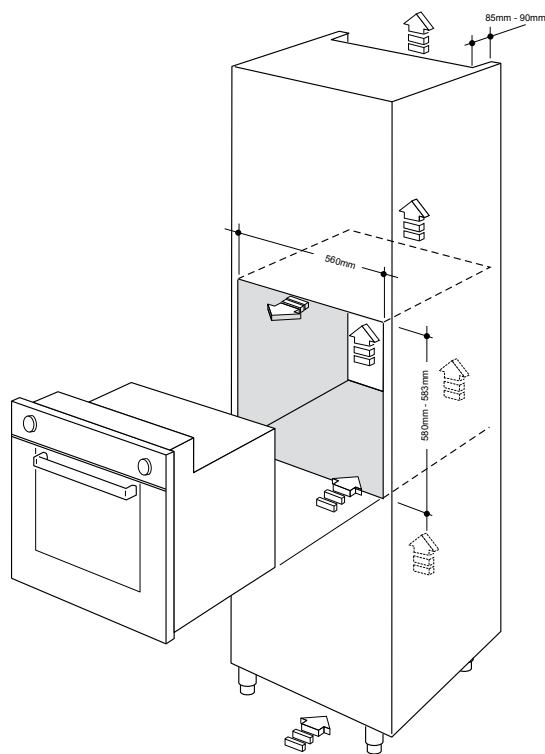
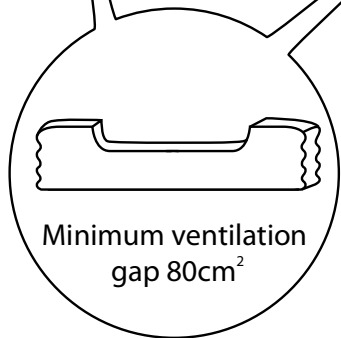
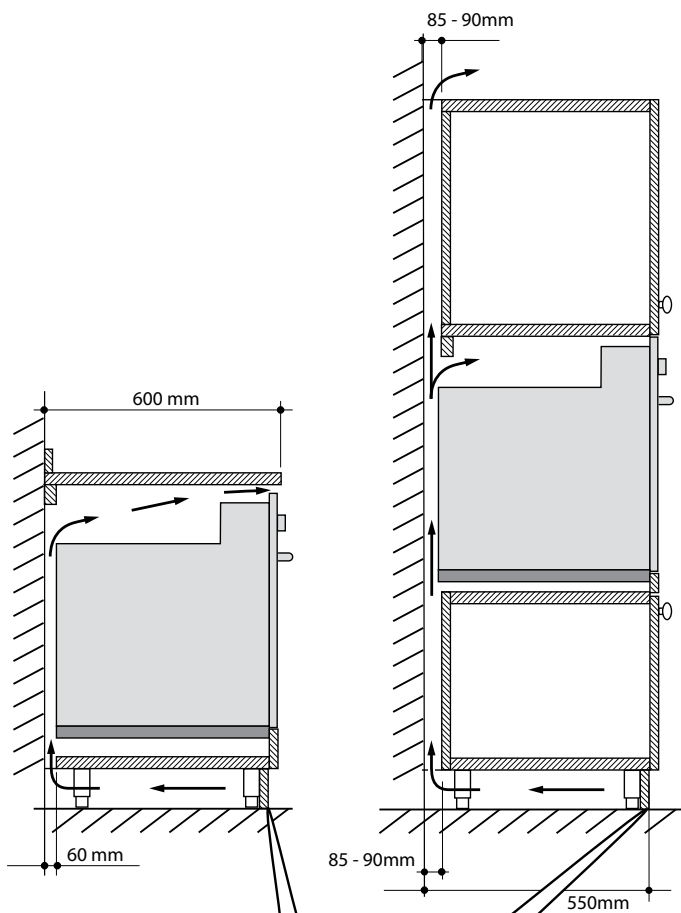
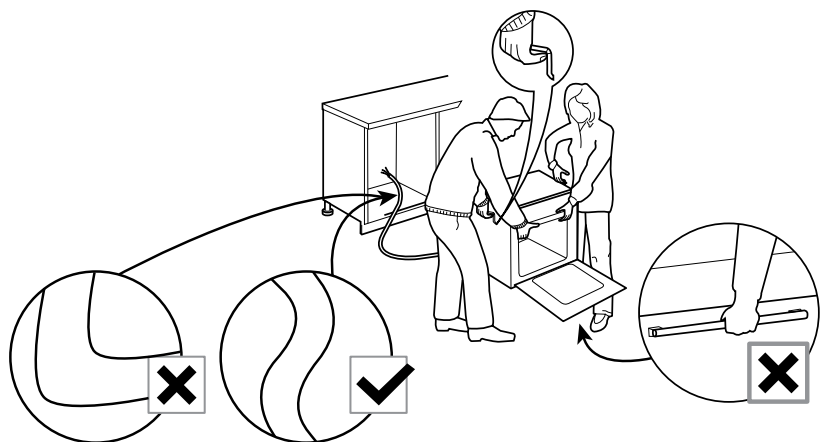

FIG.4



01



02



[06] x 4

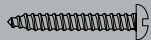

[07] x 4

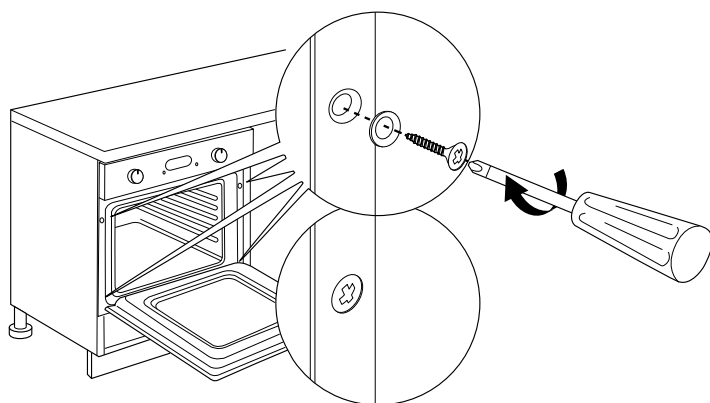

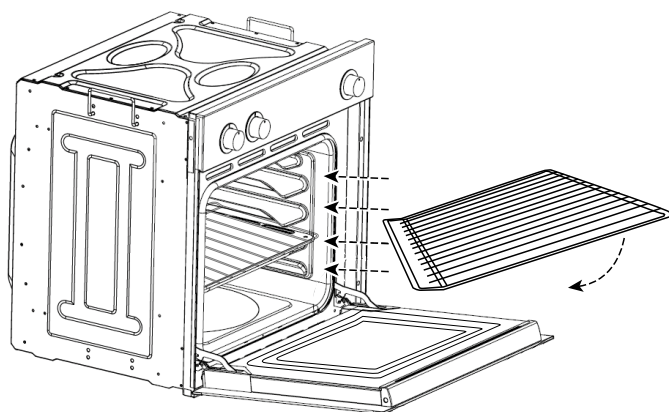

Adjusting the shelf position

Note: For electrical connection see **Technical and legal information** section

Notes



CNA Trading U.K. Ltd
Hillbrow House
Hillbrow Road
Esher
Surrey
KT10 9NW
